

TANNOY®



V12

The V12 is a premium quality installation cabinet based around a high power 300mm (12") point source, constant directivity Dual Concentric™ transducer.

The V12 incorporates the latest generation Dual Concentric driver design. The features include a reinforced paper cone and double rolled cambric surround for high sensitivity, dual magnet assembly and a Tulip WaveGuide™ for the HF unit. The high frequency (HF) and low frequency (LF) sources are coincidentally aligned to a point source. The result is a smooth, uniform frequency response over a wide coverage area, unachievable with discrete, two-way designs in the vertical plane where massive cancellations appear off axis at the crossover frequency. The 90° conical dispersion of the Dual Concentric allows either vertical or horizontal mounting without compromising sound quality.

Available in Black or White, the rugged multi-ply birch cabinet has an asymmetric profile that allows installations in a variety of configurations.

The V12 is designed to function properly without the use of any controller. A compatible controller will equalise the system resulting in improved bass performance, enhanced HF response as well as providing a 2-way crossover function (the Tannoy TX2 controller would cross over at 100Hz) for use with separate V Series bass systems.

The V12 comes complete with a carrying handle and 10mm flying points to provide a quick and secure flying system. Tannoy's proprietary Secure-ET™ modular mounting hardware provides the V Series with multiple hanging options - wall mount, yoke, ceiling saddle, pole clamp, pole mount and eyebolts.

See the V Hardware specifications for details.



V SERIES

V SERIES
V SERIES
V SERIES
V SERIES
V SERIES

FRONT DETAIL



CABINET DETAIL

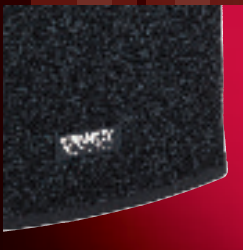

MOUNTING HARDWARE



CONNECTOR PLATE



V12

SYSTEM

System Type	Full Range - Vented	
Frequency Response (1)	+/- 3dB -10dB	70Hz - 25kHz 51Hz (38Hz with controller)
Recommended Amplifier Power	200 - 400 Watt / 8Ω	
Power Handling (2)	Average Programme Peak	200 Watt 400 Watt 800 Watt
Sensitivity 2.83 Volts @ 1 metre (3)	Anechoic Half Space	97dB 100dB
Maximum SPL	Average Peak	120dB 126dB
Impedance	8Ω	
Dispersion (-6dB)	See Beamwidth Plot	90° Conical
Driver Complement	1 x 300mm (12") Dual Concentric™	
Crossover	Passive 1.4kHz	

CONSTRUCTION

Enclosure	37.5 litre vented, 15mm (5/8") birch plywood and 15mm (5/8") MDF front baffle with perforated black steel grille covered with foam	
Finish	Textured Black or White paint	
Connectors	2 x Neutrik™ Speakon (NL4MP)	
Fittings	1 x recessed carrying handle Blanking plate for optional VTH pole mount 8 x M10 flying mount inserts 1 x M10 bracket inserts 8 x M10 yoke bracket inserts	
Dimensions	486 x 370 x 375mm (19 1/8 x 14 1/2 x 14 3/4")	
Weight (each)	20kg (44lbs)	
Shipping	Quantity Weight Pack Dimensions	1 23kg (50lbs 10oz) 660 x 521 x 495mm (26 x 20 1/2 x 19 1/2")

FRONT & REAR ELEVATION

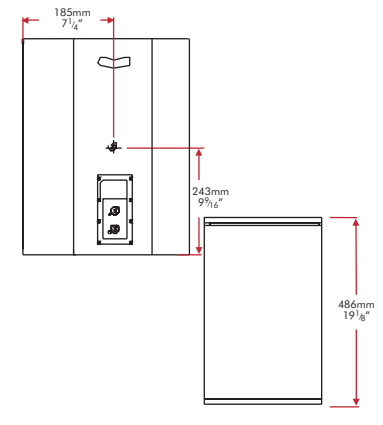

TOP & BOTTOM ELEVATION

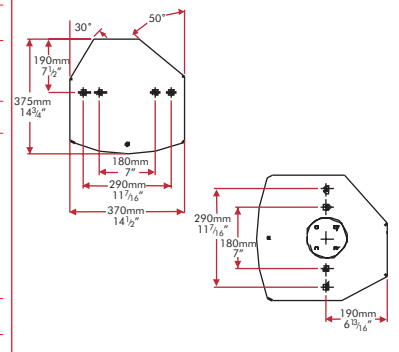

BEAMWIDTH PLOT

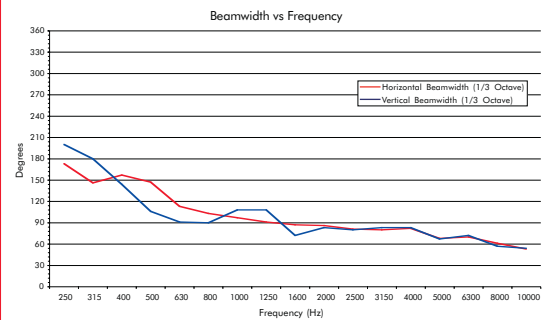

NOTES: (1) Average over stated bandwidth. Measured at 1 metre on axis. (2) Long term power handling capacity as defined in EIA standard RS - 426A. (3) Unweighted pink noise input, measured at 1 metre in an anechoic chamber

A full range of measurements, performance data, and Ease™ Data can be downloaded from www.tannoy.com

Tannoy operates a policy of continuous research and development. The introduction of new materials or manufacturing methods will always equal or exceed the published specifications, which Tannoy reserves the right to alter without prior notice. Please verify the latest specifications when dealing with critical applications.

V12

APPLICATIONS

- Live sound reinforcement
- High quality public address
- Theme pubs / nightclubs
- Theatre front of house and effects
- Movie theatre / cinema
- Side fill in large - scale music reinforcement
- Theme parks and leisure venues
- Sports and multi - use stadiums
- Audio visual
- Religious facilities

FEATURES

- 300mm (12") point source Dual Concentric driver
- 90° controlled conical dispersion for optimum coverage and forward gain
- Compact, versatile enclosure
- High power handling
- High efficiency and low distortion
- Rugged birch plywood construction
- Convenient aspect ratio
- Integral carrying handle
- Integral flying points
- Secure-ET™ mounting options
- Five year loudspeaker warranty

ARCHITECTURAL SPECIFICATIONS

The loudspeaker shall consist of a 300mm (12") full range, single point source Dual Concentric™ transducer. The low and the high frequency elements shall be combined by an internal passive crossover network operating at 1.4kHz, with 2nd order high pass, 2nd order low pass. Performance of the loudspeaker, without any electronic control shall meet or exceed the following criteria: Frequency response measured at 1 metre on axis with swept sine wave shall be 70Hz - 25kHz (+/-3dB). Sensitivity shall be at least 97dB (anechoic) for 2.83 Volts @ 1 metre and shall be capable of producing a peak output level of 126dB (anechoic) on axis at 1 metre. The dispersion of the loudspeaker shall be 90° conical (-6dB). The system shall have a nominal impedance of 8Ω, maximum power handling shall be 400 Watts (programme). The enclosure shall be an optimally tuned (37.5 litre), vented enclosure of birch plywood construction. The enclosure shall be fitted with an integral carrying handle, and integral M10 mounting points for flying hardware. The enclosure shall not exceed the following dimensions: 486 x 370 x 375mm or 19 1/8 x 14 1/2 x 14 3/4" (H x W x D). The loudspeaker shall be the Tannoy... V12



Tannoy United Kingdom | T: +44 (0) 1236 420199 | F: +44 (0) 1236 428230 | E: enquiries@tannoy.com
 Tannoy North America | T: (519) 745 1158 | F: (519) 745 2364 | E: enquiries@tannoyna.com

tannoy.com